

Renault Megane 2
 Alternate Electric
 Window Control Unit
 Revision 1

Colour Key:
 BL – Black
 R – Red
 BR – Brown
 WH – White
 GR – Green
 Y – Yellow
 M - Window Motor

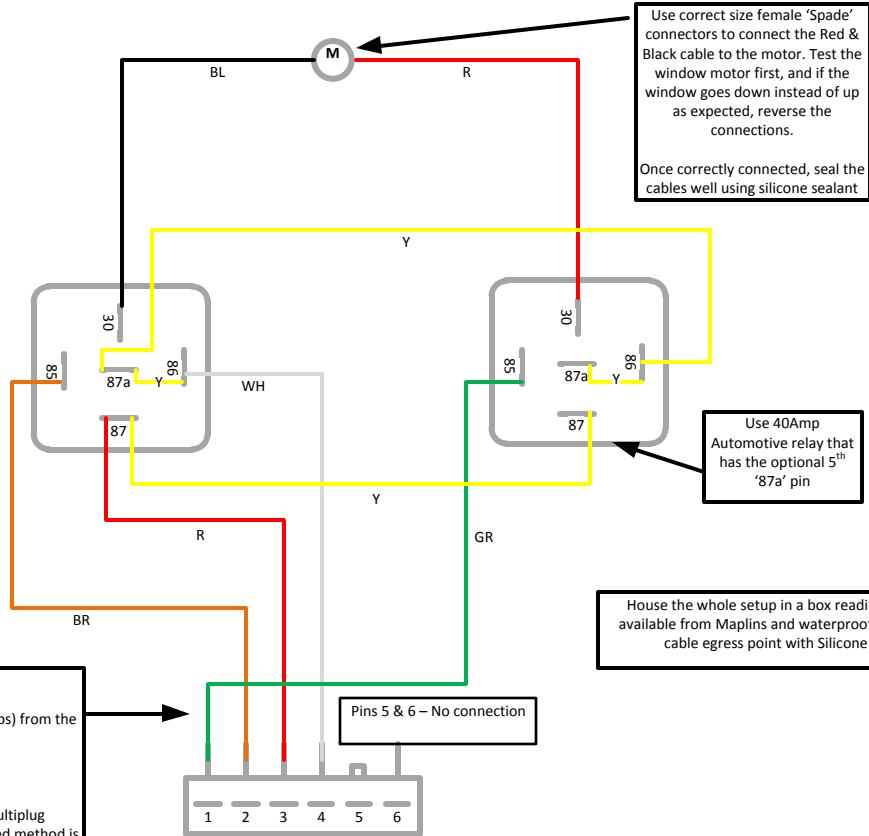

Use correct size female 'Spade' connectors to connect the Red & Black cable to the motor. Test the window motor first, and if the window goes down instead of up as expected, reverse the connections.
 Once correctly connected, seal the cables well using silicone sealant

Use 40Amp Automotive relay that has the optional 5th '87a' pin

House the whole setup in a box readily and cheaply available from Maplins and waterproof the box seal & cable egress point with Silicone Sealant.

Note: Connecting the new Controller.
 Remove the old control unit (1 screw and two clips) from the side of the Window Motor.
 Connecting the wiring:
 Option 1: Cut the cables to the Megane's multiplug connecting to original Control Unit. Recommended method is to Solder the new cables to the original & Seal with Heat Shrink.
 Option 2: Find 'Spade' plugs in Car Spares shop that fit the multiplug. Take care to waterproof the plug if this option is taken.
 Finally, secure the new controller setup to the door using Cable Ties or self-tapping screws – Rust proof the area afterwards if you use screws!

Pins 5 & 6 – No connection